

CALIFORNIA GOLD PRODUCTS

www.calgoldproducts.com

HMMWV Specialists

(805) 484-9408

Fax: (805) 987-8674

Pager: (866)-225-0133

P.O. Box 1933,
Camarillo, CA 93011

E-mail: gharris333@aol.com

SlantBack™
WagonBack™
Accessories
Custom

Glenn Harris
Owner

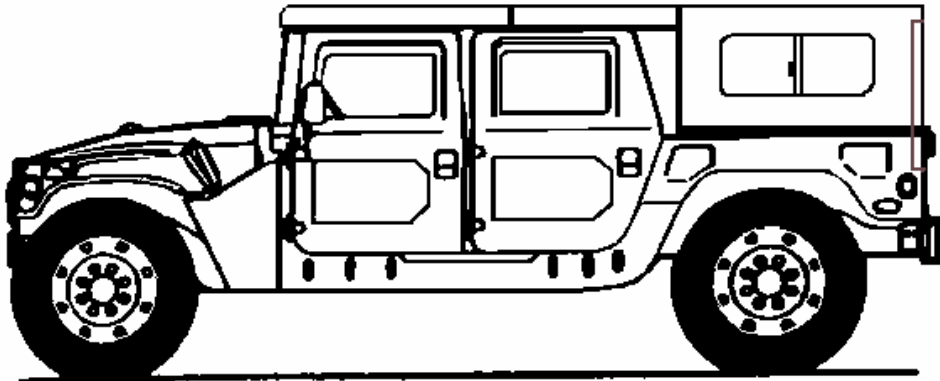

WagonBack™

Top Kit Installation

INTRODUCTION

- Removable
- Light Weight
- All Aluminum
- Weather Tight
- Easy to Install
- Secures Vehicle
- Lockable
- Modular

Your new *California Gold Products* HMMWV weather tight Top Kit consists of six (7) major components. The easy to assemble Top Kit was designed to allow the top to be easily taken on or off to meet prevailing weather conditions. Once removed the modular hard shell top is easily stored.

The Top Kit includes a Front Section, Mid-Section, Side panels (both Driver and Pass.), WagonBack, Tail Gate Fillers and Rear Door. Easy to assemble windows are included for the WagonBack and Rear Door. All necessary hardware is included for installation.

Inspect your Top Kit against the packing list enclosed. Should there be missing components call *California Gold Products* (805) 984-4804.

To speed up installation time match up parts with related components before beginning installation.

PARTS

Part #	Description	Quantity
TK1	Front Section	1
TK2	Mid-Section	1
TK2-1	Front and Rear Top Support	4
TK3	Side Panel, Driver	1
TK4	Side Panel, Pass.	1
TK5	WagonBack	1
TK5-1	AVK 5/16" nut insert	11
TK5-2	Tailgate Filler, Pass.	1
TK5-3	Tailgate Filler, Drvr.	1
TK5-4	WagonBack Door	1
TK5-5	Window, Side	2
TK5-6	Window, Rear	1
TK5-7	Latch	1
TK5-8	Latch Rod	2
TK5-9	Latch Guide	2
TK5-10	Lock	1
TK5-11	Hydraulic Door Lift	2

TK5-12	Hydraulic Door Lift Lower Mounting Bracket	2
TK5-13	Hydraulic Door Lift Upper Mounting Bracket	2
TK5-14	Hinge, Stainless	3
TK5-15	Latch Rod Cover	1
TK6	Weather Seal, Round	1
TK7	Weather Seal, Flat	1
WBHP01	Hardware Pack:	
B516	5/16" x 1-1" Bolts	11
W516	5/16" Flat Washers	7
N516	5/16" Nyloc Nuts	2
N14	1/4"-20 Nuts	40
W14	1/4" Flat Washers	4
S8	10/32" x 1/4" Screws	42

INSTALLATION

1) Remove the factory soft top. Pull the top's side and back edges away from vehicle to separate the Velcro style hoop and loop fasteners. Unsnap the roll bar straps. The top's front edge is secured via a channel. Once all fasteners are released slide front of top to one side working the top's leading edge out of channel.

2) On early models, remove both sun visors from windshield frame. If equipped with a monsoon console remove the 11 screws securing the console's plastic top then remove plastic top.

3) Remove the *California Gold Products* hard top from its shipping container. Lay sections out as shown in **Illustration 1**.

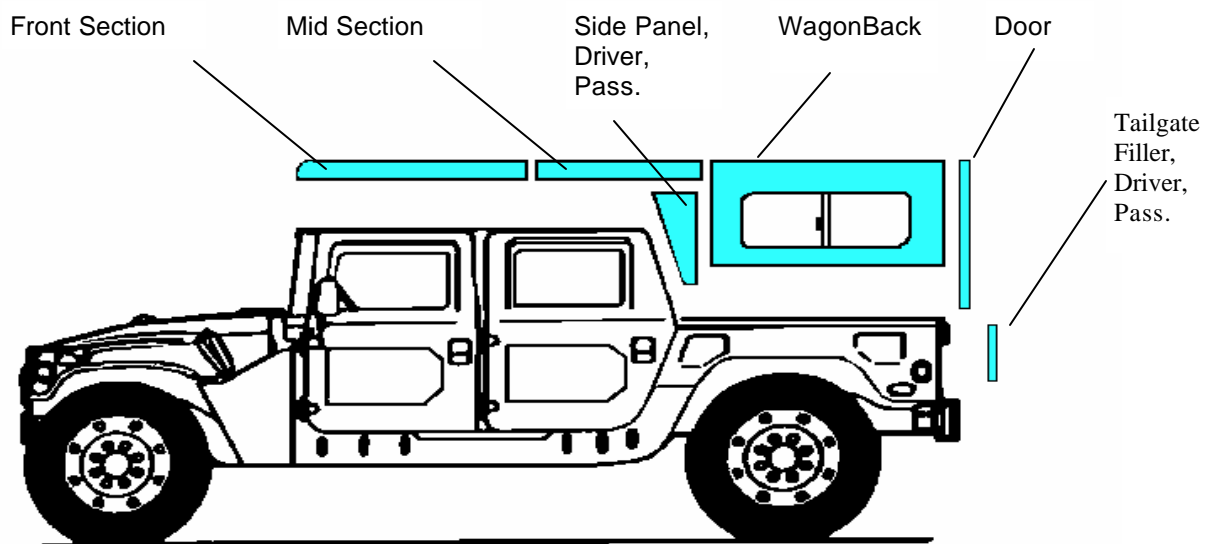

Illustration 1

4) Measure and cut half-round Weather Seal (TK6) the full length of both Front and Mid-Sections. Begin at the windshield support and measure back to top edge of rear door's top support. Remove sticky back cover from Seal and attach Seal over existing soft top's hook-n-loop material as shown in **Illustration 2**.

5) Repeat Step 4 on both the Driver and Passenger's side of vehicle.

6) On 1998 and newer models the top's Front Section installs over existing weather seal attached to top of windshield frame (**Illustration 3**). On 1997 and earlier models measure and cut half-round Weather Seal (TK6) the full length of the windshield frame and attach seal to frame. The Brackets will align with the existing sun visor or monsoon console mounting holes located on the inside top edge of the windshield frame.

7) Loosely install sun visors and Front Section's Brackets as an assembly using existing hardware. Do not tighten yet.

8) Cut the flat Weather Seal (TK7) to length along back edge of Front Section. Press Seal against studs extending from backside edge of Front Section to mark hole holes in Seal to clearance for studs. Install Weather Seal onto studs.

9) Align mounting holes on front edge of Mid-Section to studs on backside of Front Section. Connect Front and Mid-Section with Flat Washer and 1/4"-20 Nyloc Nuts on each of the studs (**Illustration 4**). Do not tighten yet.

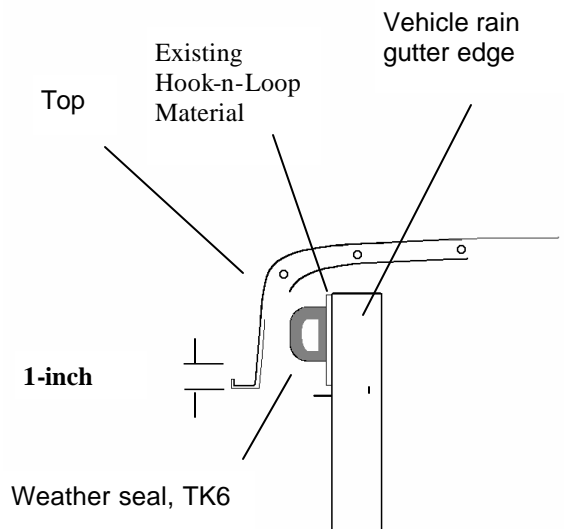

Illustration 2
attached front edge

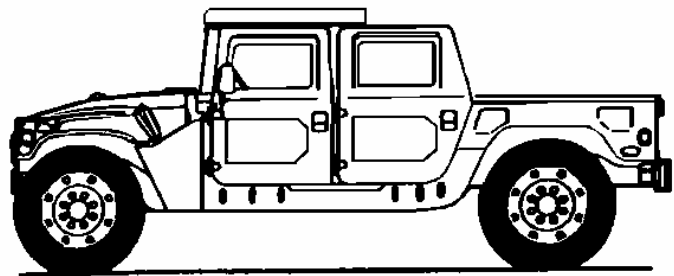

Illustration 3
locations. Punch

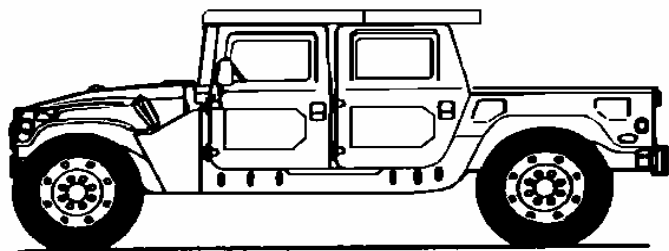

Illustration 4

10) Install roll bar Top Support (TK1-1) to top (**Illustration 5**). Insert the flat end of support into slot of bracket made into top section. Swing opposite end of support up, and around, padded roll bar. Attach Support to top's bracket using 1/4-20" x 3/4" Hex Bolt and Flat Washer into threaded insert. Do not tighten yet.

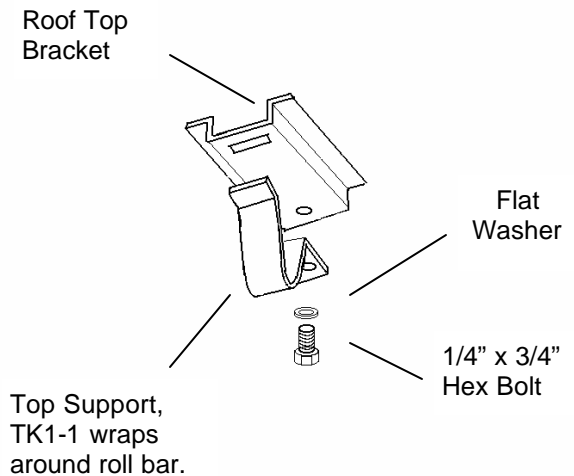

Illustration 5

11) Insert Side Panel (TK3, Driver) under rear edge of Mid-Section with studs on Side Panel facing rear of vehicle (**Illustration 6**).

12) Insert Side Panel (TK4, Passenger) under rear edge of Mid-Section with studs on Side Panel facing rear of vehicle.

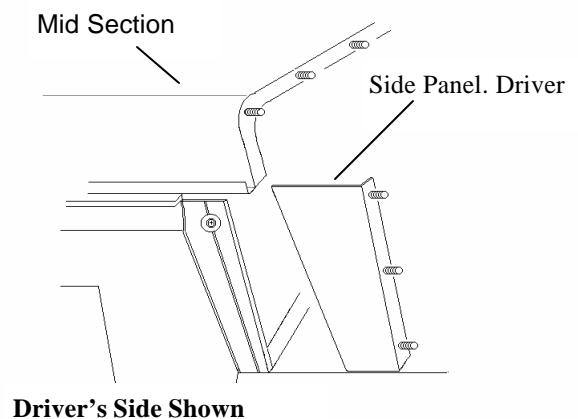

Illustration 6

13) Install roll bar Top Support (TK2-1) to rear of Mid-Section. Insert the flat end of support into slot of bracket made into Top. Swing opposite end of support up, and around, padded roll bar. Attach Support to top's bracket using 1/4-20" x 3/4" Hex Bolt and Flat Washer into threaded insert. Do not tighten yet.

14) Remove the existing tailgate by removing the three (3) external hinge bolts on each side of tailgate. To prevent loss of parts replace tailgate hinge-shims and bolts.

15) Cut flat Weather Seal (TK7) to length along back edge of Mid Section. Press Seal against studs extending from backside edge of Mid Section to mark hole locations. Punch holes in Seal to clearance for studs. Install Weather Seal onto studs (**Illustration 7**).

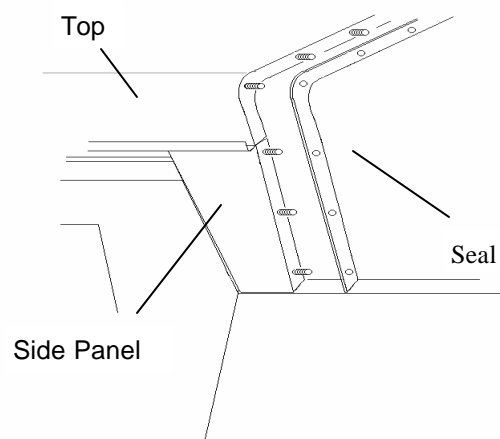
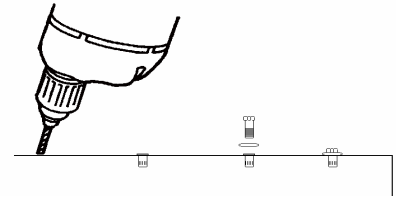

Illustration 7

16) Temporarily set WagonBack onto vehicle. Align holes in front edge of WagonBack to studs on Mid-Section. Mark mounting holes on bottom edge of WagonBack then remove WagonBack. Drill 1/4" holes where marked. Use nut insert rivet tool to install supplied 1/4" threaded insert into holes drilled (**Illustration 8**).



1. Mark and drill mounting hole.
2. Use nut insert tool to install nut insert.
3. Align top and install bolt with flat washer.
4. Assure top is aligned and tighten all bolts.

Illustration 8

17) Cut to length and install half-round Weather Seal (TK6) onto bottom edge of WagonBack. Punch through Seal where mounting holes exists.

18) Install WagonBack by aligning holes in front of WagonBack to studs on Mid-Section and Side Panels (**Illustration 9**). Install with Flat Washer and 1/4"-20 Nut on studs. Do not tighten yet.

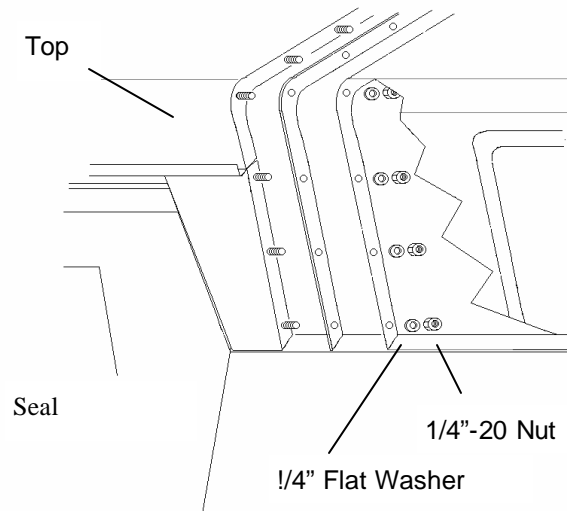

Illustration 9

19) Ensure top is properly aligned. Check along edges and hand start all 1/4"-20 x 1-1/4" bolts to secure bottom of WagonBack to vehicle. Once all nuts and bolts are started tighten all 1/4" Nuts (on both Front and Mid-Sections) to 7 ft. lbs.

20) Inside vehicle, tighten sun visor/Top Section anchor bolts. If equipped, install Monsoon Console plastic top. It will be necessary to trim top to clearance Front Section Brackets.

21) Position Tailgate Filler (TK5-2 Pass. & TK5-3 Driver) to corner edge of bed as shown in **Illustration 10**. Mark mounting hole locations. Remove Filler and drill 1/4" holes where marked. Use nut insert tool to install threaded inserts.

Tailgate Filler, Driver Tailgate Filler, Pass.

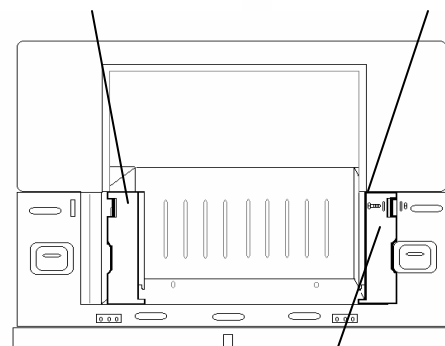

NOTE: Tuck existing tailgate chain behind Filler.

5/16" Bolt, Washer & Nut

Illustration 10

22) Install Ball Stud to Tailgate Filler and to tab on upper edge of Wagonback Door (**Illustration 11**). The Ball Stud mounts into 5/16" nut insert.

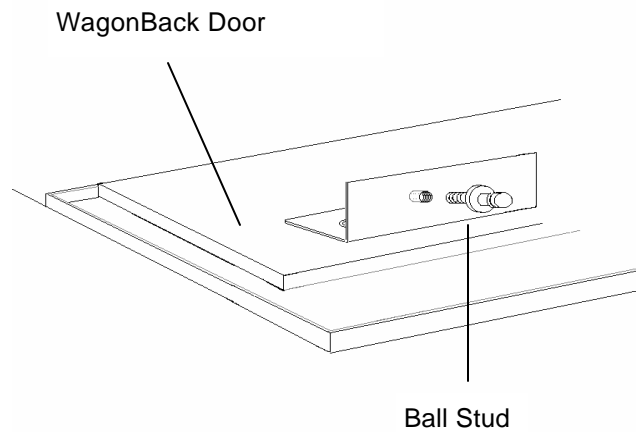

Illustration 11

23) Install Tailgate Filler on each appropriate side of tailgate opening. Tuck tailgate chain behind Filler. Secure Filler to vehicle using 10/32" Hex Bolts and Flat Washers.

24) Install Side Window (30-03) into WagonBack window opening (**Illustration 12**). First install window's 1/4-inch gasket material to the inside edge of window frame. Insert window/gasket assembly into opening. Install window gasket to interior window support ring and install assembly from inside WagonBack. Use 10/32" x 1-1/4" Phillips Head Screws provided and secure supporting ring to the window.

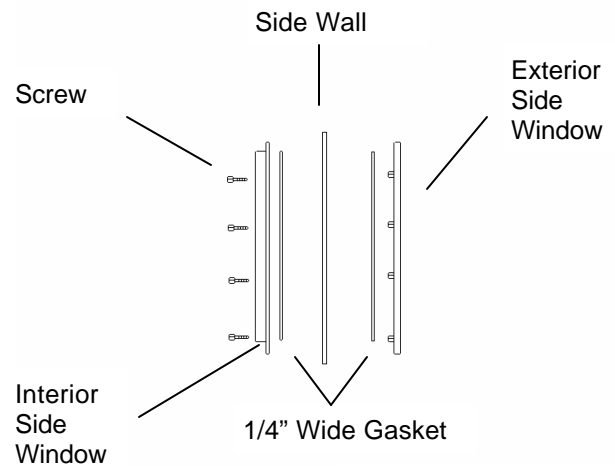

Illustration 12

25) Repeat Step 24 on opposite side of WagonBack.

26) Repeat Side Window installation procedure for WagonBack Door Window (30-04).

27) Install T-Handle Latch (TK5-7) into Rear Door so T-Handle can be pulled out and twisted clockwise to open door (**Illustration 13**). Use four (4) 1/4"-20 x 3/4" Bolts, Washers and Nuts to secure Latch to Door. Tighten 1/4" Nuts to 7 ft. lbs.

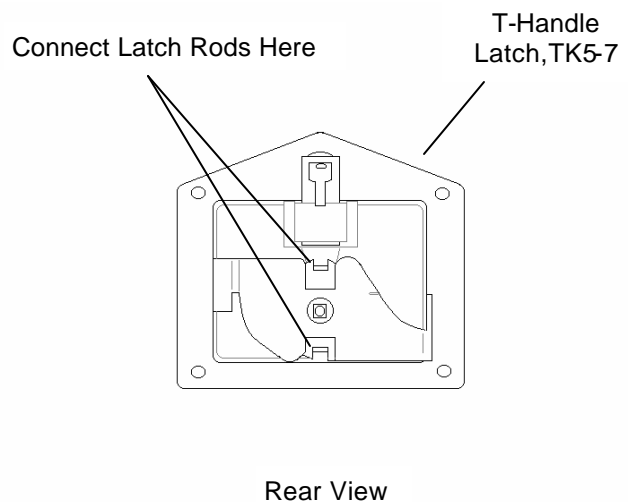

Illustration 13

28) Use 7/8" open end wrench to remove Lock assembly from Latch.

29) Position nubs on back of T-handle vertically as shown in **Illustration 13**. Insert round hole, on flat end of Latch Rod, onto top nub of T-handle Latch. Position the other Latch Rod onto the lower nub of the Latch. Insert round end of each Latch Rod into Latch Rod Cover's pre-drilled hole on each end of cover.

30) Install Lock assembly (TK5-10) into Latch.

31) Align pre-drilled holes in WagonBack with Hinge provided (**Illustration 13**). Loosely install Hinge to WagonBack using 10/32" x 1/4" Screws. Longer 10/32" x 1/2" screws are provided for Hinge to Door mounting.

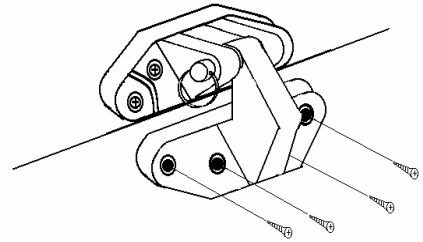

Illustration 13

32) Install Rear Door (**Illustration 14**). Position Rear Door to WagonBack with mounting holes in Hinge aligned to holes in Rear Door. Hold door in position and install Hinge using 10/32" x 1/4" Phillips Head Screws.

33) Open Rear Door. Hold door open and install Hydraulic Door Lift to Lower and Upper Mounting Brackets. Secure Hydraulic Door Lift to Brackets with clip provided. Insert Lift's Ball Socket over Ball Stud. Insert Clip into small hole on Lift's Ball Socket. Latch Clip around Ball Socket.

NOTE: Do not attempt to support Door with just one Hydraulic Door Lift. Make sure both Lifts are attached.

34) Install Latch Rod Cover over Latch Rod assembly. Secure Cover to inside edge of Rear Door using 1/4"-20 Hex Bolts provided. Torque bolts to 7 ft. lbs.

35) Align door assembly and make sure all fasteners are tight.

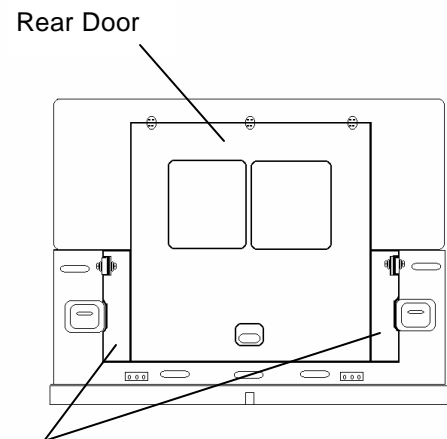

California Gold Products

Tail gate filler

Illustration 14

TOP REMOVAL

Your California Gold Products weather tight Top is both functional and versatile. You can achieve various Top configurations by independently removing separate sections of the Top.

NOTE: Although made of light-weight material it is recommended the Wagonback be lifted by two people. Do not lift WagonBack with rear door attached.

- 1) From inside WagonBack (rear door closed) remove clip securing Hydraulic Door Lift to Lower and Upper Mounting Bracket ball studs. The clip pulls back (away from Lift) then down. Once clips are removed pull Hydraulic Door Lift away from ball studs.
- 2) Prevent the door from falling forward and remove screws (4 each hinge) securing Rear Door Hinge to WagonBack.
- 3) Pull up on Latch and lift Rear Door from WagonBack.
- 4) From inside WagonBack, remove the ¼” Nuts and Flat Washers securing WagonBack to Mid-Section and Side Panels. Remove 5/16” Bolts securing bottom of WagonBack to vehicle. Lift WagonBack from vehicle.
- 5) Remove side Panels by pulling back and down from Top.
- 6) Remove roll bar Front and Rear Top Supports from roll bar.
- 7) From inside WagonBack, remove ¼” Nuts securing Mid-Section to Front Section of Top. Pull back and up to remove Mid-Section from vehicle.

CAUTION: Take care when removing Sections so not to damage weather seal.

8) Remove sun visors. This will disengage the Top's front bracket. Ensure Bracket is unhooked and lift Front Section straight up.

9) Replace sun visors.